

In addition to the pump itself, pressurised water systems require an inlet strainer and a pressure reservoir (accumulator tank) for smooth, reliable operation. The **Par-Max MAXI-SYSTEM 3 + 2** combines them all in one compact unit. No time-consuming assembly work – just 4 mounting screws, 2 electrical leads and 2 pipe connections.....and the job's done.

Par-Max MAXI-SYSTEM 3 + 2 offers savings all-round!

- ◆ Jabsco's high flow 'Par-Max' pump: powerful, quiet and inexpensive
- ◆ Ultra-simple to install, using 15mm Hep₂0 push-fit pipework
- ◆ Pressure switch cuts in at 10 psi, out at 25 psi
- ◆ Ample flow for up to 4 outlets in small/medium sized boats

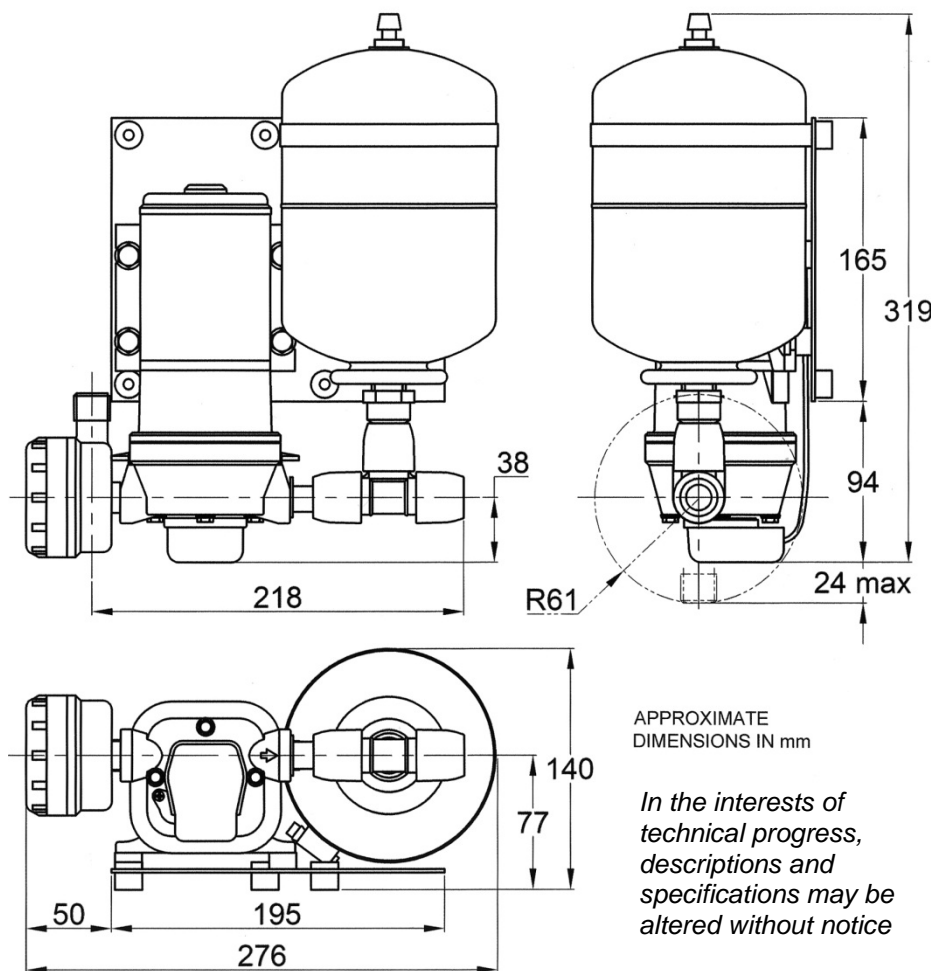

Model no	Volts dc	Amp draw	Fuse size amps
CW299A	12	5.0	10
CW300A	24	3.0	7

Cut-in pressure	10 psi (0.7 bar)
Cut-out pressure	25 psi (1.7 bar)

CLEGHORN WARING

MAXI-SYSTEM 3+2 PRESSURISED WATER SYSTEM 12 AND 24 VOLTS DC



- ◆ Up to 13.2 litres/minute (2.9 gallons/minute) for up to 4 outlets in small / medium sized boats
- ◆ Includes 2 litre accumulator tank and inlet strainer
- ◆ Smooth flow
- ◆ Quiet
- ◆ Easy to fit – pre-assembled for ultra-simple installation
- ◆ Quick and easy Hep₂0 push-fit pipe connections